



S
I
S
I
E

BRITISH STANDARD CHAINS,
BS 4116 PART 4 (Z series)



BRITISH STANDARD CHAINS, BS 4116 PART 4

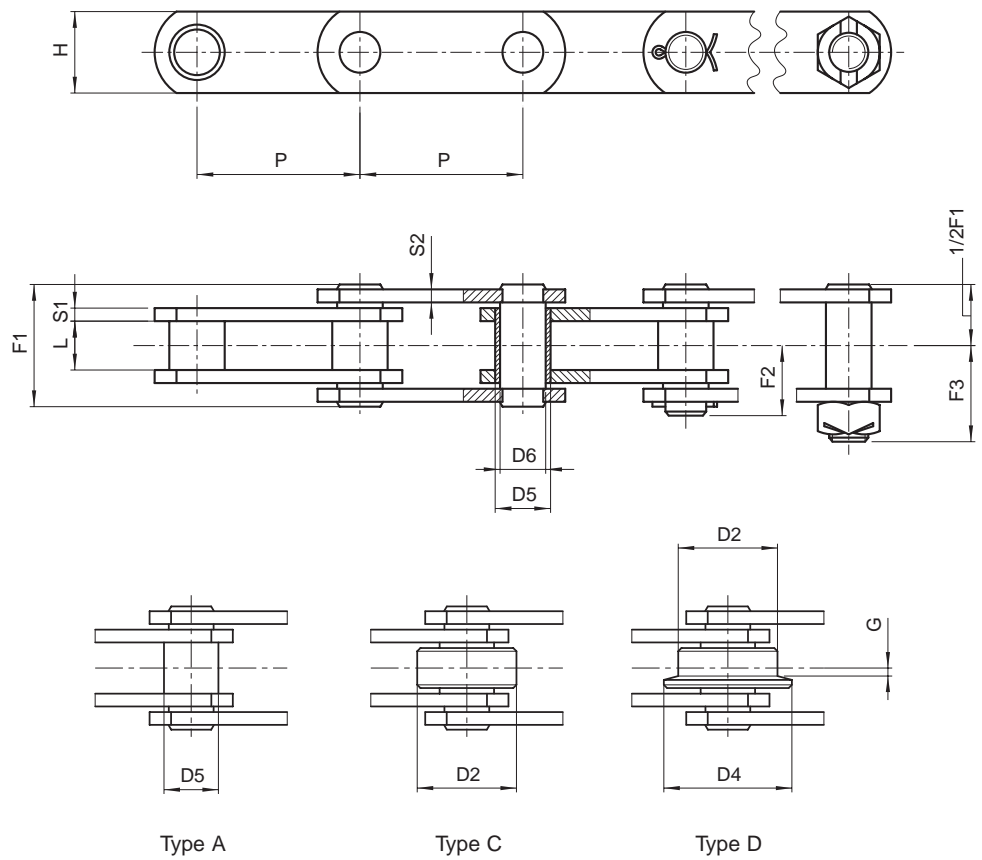

SOLID PIN CHAINS

Chain N.	P inches	P mm	L mm	D2 mm	D4 mm	G mm	D5 mm	D6 mm	H mm	S1 mm	S2 mm	F1 mm	F2 mm	F3 mm	Breaking load	
															N	N*
7500 lbf Z40	2	50,8	15	31,75	40	2,5	17	14	25	4	4	37	22	28,5	40.000	50.000
"	2,5	63,5	"	"	"	"	"	"	"	"	"	"	"	"	"	"
"	3	76,2	"	"	"	"	"	"	"	"	"	"	"	"	"	"
"	3,5	88,9	"	"	"	"	"	"	"	"	"	"	"	"	"	"
"	4	101,6	"	"	"	"	"	"	"	"	"	"	"	"	"	"
"	5	127	"	"	"	"	"	"	"	"	"	"	"	"	"	"
"	6	152,4	"	"	"	"	"	"	"	"	"	"	"	"	"	"
15000 lbf Z100	3	76,2	19	47,5	60	3,5	23**	19	40	5	4	45	28	37	100.000	130.000
"	3,5	88,9	"	"	"	"	"	"	"	"	"	"	"	"	"	"
"	4	101,6	"	"	"	"	"	"	"	"	"	"	"	"	"	"
"	5	127	"	"	"	"	"	"	"	"	"	"	"	"	"	"
"	6	152,4	"	"	"	"	"	"	"	"	"	"	"	"	"	"
"	7	177,8	"	"	"	"	"	"	"	"	"	"	"	"	"	"
"	8	203,2	"	"	"	"	"	"	"	"	"	"	"	"	"	"

(*) Breaking load with heat treated plates

(**) Ø 24 mm. for chain type "A"

Additional features:

- metric pitch
- rollers of nylon, delrin, etc.
- with extended pins
- in STAINLESS steel
- surface treatments of zinc plating, nickel plating, etc.
- pre-tensioned and labelled

BRITISH STANDARD CHAINS, BS 4116 PART 4

ALTERNATIVE ATTACHMENTS

- "K" TYPE ATTACHMENTS AS SHOWN
- "L" TYPE - ONE SIDE OR BOTH SIDES WELDED OR INTEGRAL.
- "F" TYPE - WITH ONE OR TWO HOLES - WELDED.
- "S" TYPE - PUSHER - ONE SIDE OR BOTH.
- "M" TYPE - VERTICAL ON INNER OR OUTER LINKS.
- "G" TYPE - ON INNER OR OUTER LINKS.
- SPECIAL ATTACHMENTS TO SUIT INDIVIDUAL APPLICATIONS.

EXTENDED BEARING PINS
 OUTBOARD ROLLERS ONE SIDE OR BOTH.
 HOLES INSIDE PLATES AS REQUIRED.

Layout of attachments
 on page 1.9/2

ATTACHMENTS

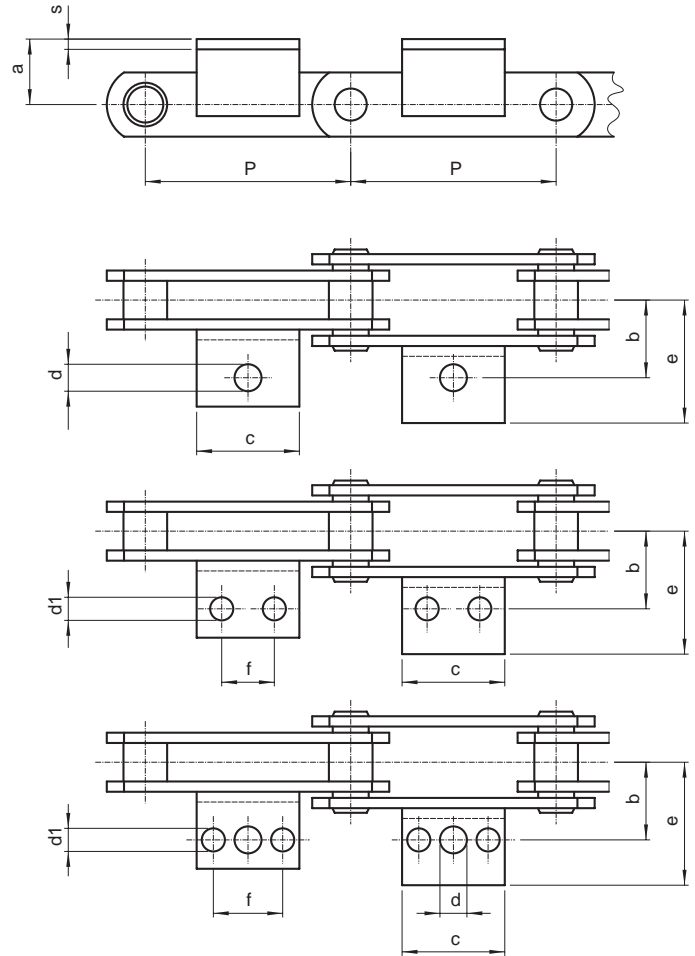

Chain N.	Symbol	P mm	a mm	b mm	c mm	d mm	d1 mm	e mm	f mm	Angle mm	Chain weight			Weight per attach. kg
											type A	type C	type D	
Z40	●⊗	50,8	19	38,1	45	10,7	/	64,5	/	/	3	4,2	4,4	0,100
"	●♣	63,5	"	"	43	"	9,3	56	22,2	40x25x4	2,8	3,8	3,9	0,100
"	□⊗	76,2	"	"	"	"	"	68	"	/	2,5	3,3	3,4	0,100
"	□	88,9	"	"	50	"	"	56	31,8	40x25x4	2,4	3,1	3,2	0,100
"	□⊗	101,6	"	"	64	"	"	55	"	/	2,3	2,9	3	0,100
"	□	127	"	"	84	"	"	56	57,2	40x25x4	2,1	2,6	2,7	0,200
"	□	152,4	"	"	"	"	"	"	"	"	1,9	2,4	2,5	0,200
Z100	●	76,2	32	44,5	30	14	/	65	/	45x5	4,9	7,7	8,2	0,100
"	●	88,9	"	"	"	"	/	"	/	"	4,7	7,1	7,5	0,100
"	□⊗	101,6	"	"	64	"	10,5	"	31,8	/	4,6	6,5	7	0,100
"	●♣	127	"	"	84	"	"	"	57,2	45x5	4,3	5,6	6,2	0,300
"	□⊗	152,4	"	"	114,5	"	"	"	"	/	4,1	5,2	5,7	0,300
"	●♣	177,8	"	"	110	"	"	"	80	45x5	3,9	4,8	5,2	0,400
"	●♣	203,2	"	"	"	"	"	"	"	"	3,8	4,6	5	0,400

- attachments with 1 hole
- ♣ attachments with 2 holes
- attachments with 3 holes
- ⊗ integral attachments

BRITISH STANDARD CHAINS, BS 4116 PART 4

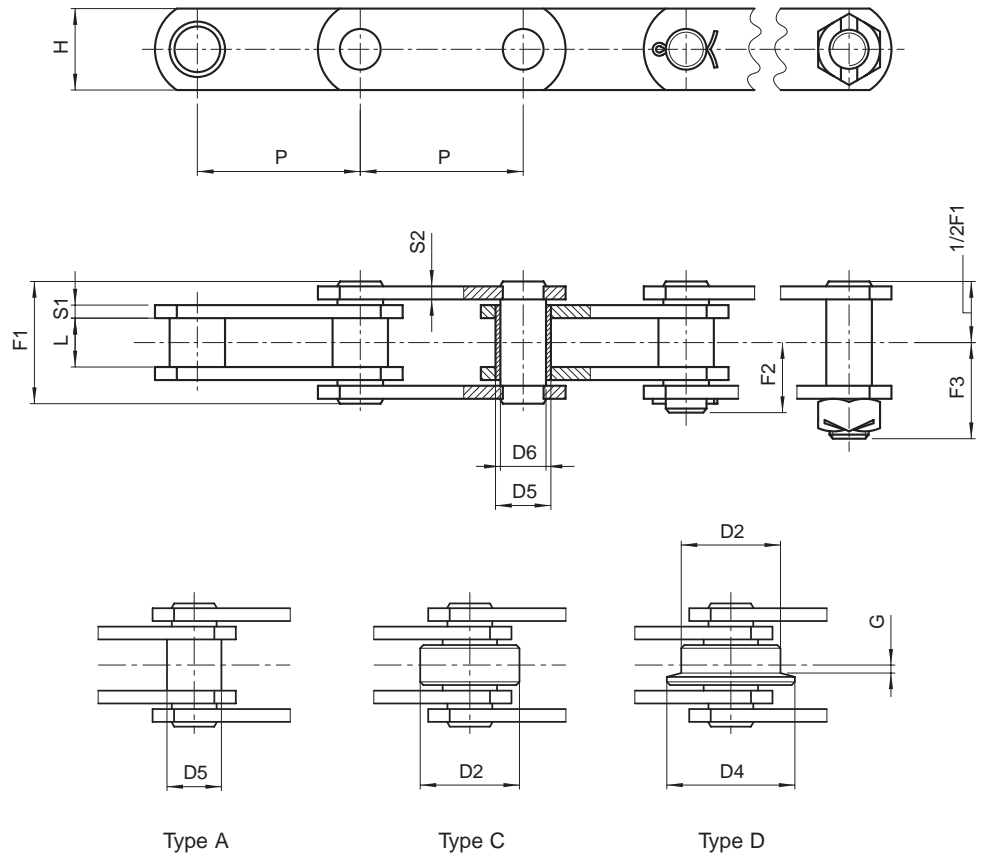

SOLID PIN CHAINS

Chain N.	P inches	P mm	L mm	D2 mm	D4 mm	G mm	D5 mm	D6 mm	H mm	S1 mm	S2 mm	F1 mm	F2 mm	F3 mm	Breaking load	
															N	N*
30000 lbf																
Z160	4	101,6	26	66,7	82	3,5	33	26,9	50	7	5	58	34,5	51,0	156.000	200.000
"	5	127	"	"	"	"	"	"	"	"	"	"	"	"	"	"
"	6	152,4	"	"	"	"	"	"	"	"	"	"	"	"	"	"
"	7	177,8	"	"	"	"	"	"	"	"	"	"	"	"	"	"
"	8	203,2	"	"	"	"	"	"	"	"	"	"	"	"	"	"
"	9	228,6	"	"	"	"	"	"	"	"	"	"	"	"	"	"
"	10	254	"	"	"	"	"	"	"	"	"	"	"	"	"	"
60000 lbf																
Z300	6	152,4	38	88,9	114	8,5	38	32	60	10	8	84	52	71,0	300.000	380.000
"	7	177,8	"	"	"	"	"	"	"	"	"	"	"	"	"	"
"	8	203,2	"	"	"	"	"	"	"	"	"	"	"	"	"	"
"	10	254	"	"	"	"	"	"	"	"	"	"	"	"	"	"
"	12	304,8	"	"	"	"	"	"	"	"	"	"	"	"	"	"

(*) Breaking load with heat treated plates

Additional features:

- metric pitch
- rollers of nylon, delrin, etc.
- with extended pins
- in STAINLESS steel
- surface treatments of zinc plating, nickel plating, etc.
- pre-tensioned and labelled

BRITISH STANDARD CHAINS, BS 4116 PART 4

ALTERNATIVE ATTACHMENTS

- "K" TYPE ATTACHMENTS AS SHOWN
- "L" TYPE - ONE SIDE OR BOTH SIDES WELDED OR INTEGRAL.
- "F" TYPE - WITH ONE OR TWO HOLES - WELDED.
- "S" TYPE - PUSHER - ONE SIDE OR BOTH.
- "M" TYPE - VERTICAL ON INNER OR OUTER LINKS.
- "G" TYPE - ON INNER OR OUTER LINKS.
- SPECIAL ATTACHMENTS TO SUIT INDIVIDUAL APPLICATIONS.

EXTENDED BEARING PINS
 OUTBOARD ROLLERS ONE SIDE OR BOTH.
 HOLES INSIDE PLATES AS REQUIRED.

Layout of attachments
 on page 1.9/2

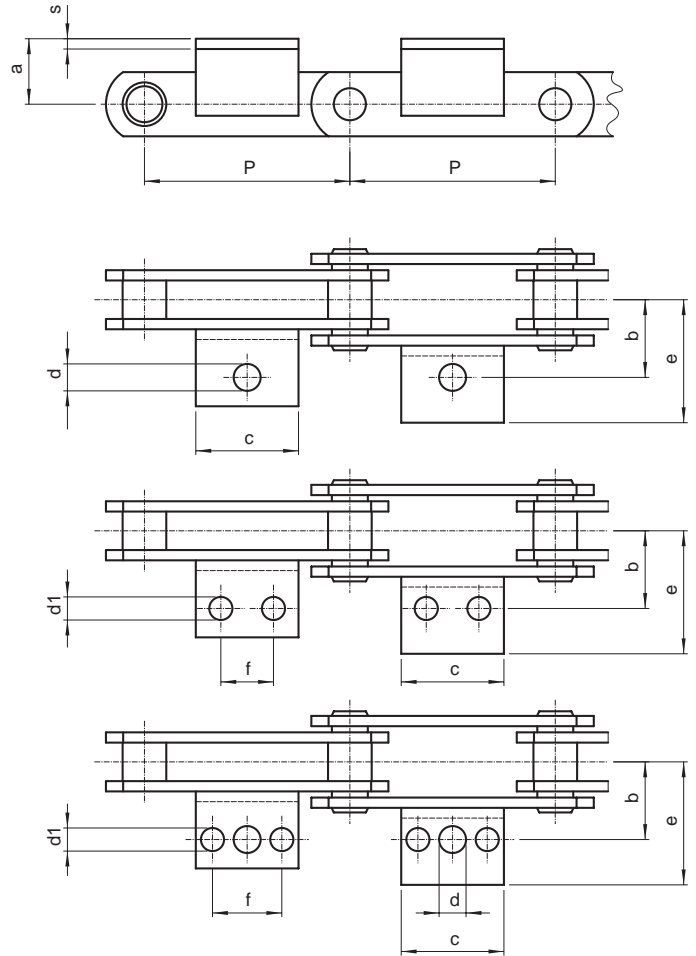

ATTACHMENTS

Chain N.	Symbol	P mm	a mm	b mm	c mm	d mm	d1 mm	e mm	f mm	Angle mm	Chain weight			Weight per attach. kg
											type A	type C	type D	
Z160	●	101,6	38	54	35	15,5	/	77	/	/	8,8	13,7	14,9	0,200
"	●♣	127	"	"	56	"	12,3	"	31,7	50x6	8	11,8	12,8	0,300
"	●♣	152,4	"	"	84	"	"	"	57,2	"	7,5	10,8	11,5	0,400
"	●♣	177,8	"	"	"	"	"	"	"	"	7	9,8	10,5	0,400
"	●♣	203,2	"	"	130	"	"	"	100	"	6,7	9,2	9,7	0,600
"	●♣	228,6	"	"	150	"	"	"	"	"	6	8,9	9,1	0,700
"	●♣	254	"	"	170	"	"	"	135	"	5,6	7,6	8,0	0,700
Z300	●	152,4	51	73	70	17	14	100	38,1	60x8	14,7	24,3	26,0	0,500
"	●	177,8	"	"	"	"	"	"	"	"	13,7	22,0	23,5	0,500
"	●♣	203,2	"	"	100	"	"	"	76,2	"	13,1	20,5	21,6	0,700
"	●♣	254	"	"	152,4	"	"	"	90	"	12,2	18,0	19,0	0,900
"	●♣	304,8	"	"	225	"	"	"	190	"	11,6	16,5	17,5	1,600

- attachments with 1 hole
- ♣ attachments with 2 holes
- attachments with 3 holes

BRITISH STANDARD CHAINS, BS 4116 PART 4

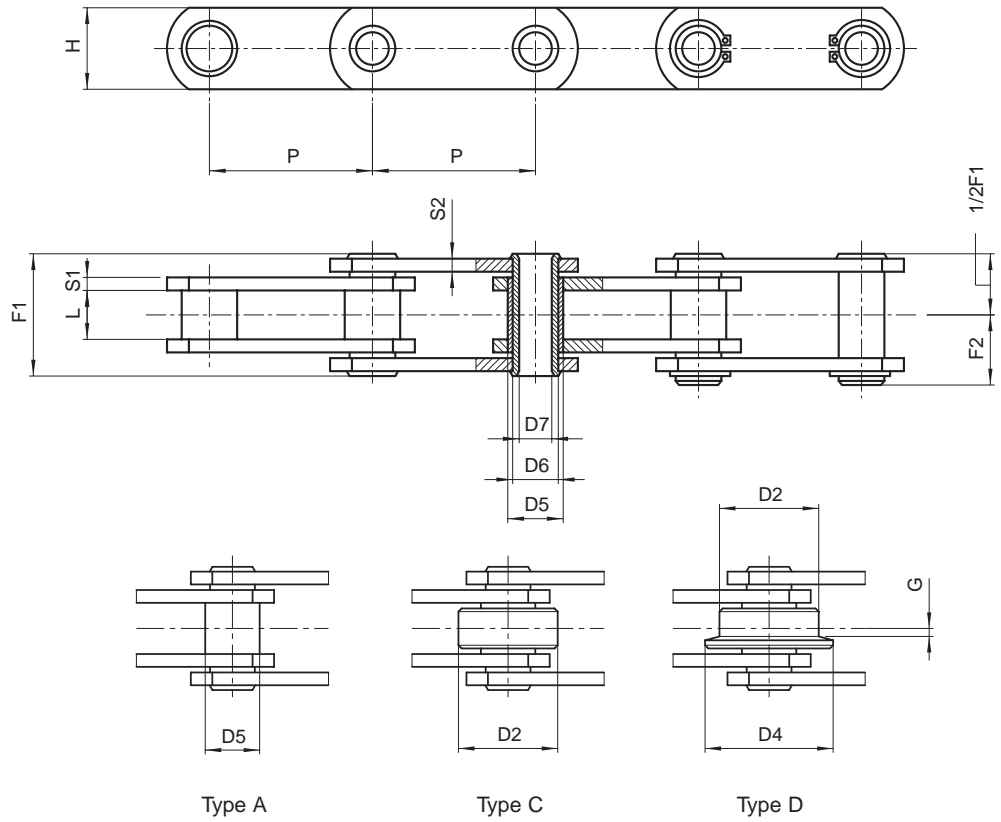

HOLLOW PIN CHAINS

Chain N.	P inches	P mm	L mm	D2 mm	D4 mm	G mm	D5 mm	D6 mm	D7 mm	H mm	S1 mm	S2 mm	F1 mm	F2 mm	Breaking load		Chain weight kg/m**
															N	N*	
4500 lbf ZC21	1,5	38,1	12,7	25,4	/	/	11	9	6,5	18	2,5	2,5	26	14,5	21.000	/	2,1
"	2	50,8	"	"	"	"	"	"	"	"	"	"	"	"	"	"	1,7
"	2,5	63,5	"	"	"	"	"	"	"	"	"	"	"	"	"	"	1,6
"	3	76,2	"	"	"	"	"	"	"	"	"	"	"	"	"	"	1,4
6000 lbf ZC40	2	50,8	15	31,75	40	2,5	17	14	10,2	25	4	4	36,4	19,5	40.000	50.000	3,6
"	2,5	63,5	"	"	"	"	"	"	"	"	"	"	"	"	"	"	3,3
"	3	76,2	"	"	"	"	"	"	"	"	"	"	"	"	"	"	3
"	3,5	88,9	"	"	"	"	"	"	"	"	"	"	"	"	"	"	2,8
"	4	101,6	"	"	"	"	"	"	"	"	"	"	"	"	"	"	2,6
"	5	127	"	"	"	"	"	"	"	"	"	"	"	"	"	"	2,4
"	6	152,4	"	"	"	"	"	"	"	"	"	"	"	"	"	"	2,3
12000 lbf ZC60	3	76,2	19	47,5	60	3,5	23☆	19	13,2	40	5	4	45	23,5	60.000	120.000	6,9
"	3,5	88,9	"	"	"	"	"	"	"	"	"	"	"	"	"	"	6,4
"	4	101,6	"	"	"	"	"	"	"	"	"	"	"	"	"	"	5,9
"	5	127	"	"	"	"	"	"	"	"	"	"	"	"	"	"	5,3
"	6	152,4	"	"	"	"	"	"	"	"	"	"	"	"	"	"	4,9
"	7	177,8	"	"	"	"	"	"	"	"	"	"	"	"	"	"	4,6
"	8	203,2	"	"	"	"	"	"	"	"	"	"	"	"	"	"	4,4

(*) Breaking load with heat treated plates

(**) Weight for chain with roller "Type C"

(☆) Diameter 24mm for chain "Type A"

- Additional features:
- metric pitch
 - rollers of nylon, delrin, etc.
 - in STAINLESS steel
 - surface treatments of zinc plating, nickel plating, etc.
 - pre-tensioned and labelled

- ZC21 stainless steel.
Sizes may differ from catalogue

BRITISH STANDARD CHAINS, BS 4116 PART 4

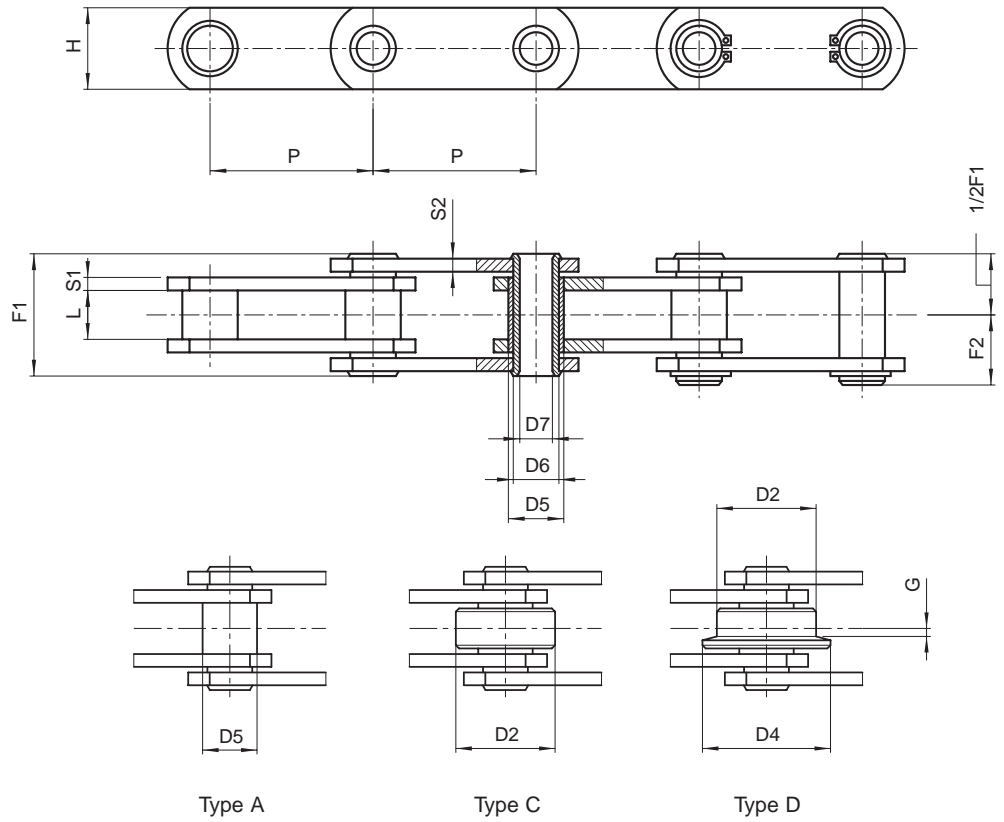

HOLLOW PIN CHAINS

Chain N.	P inches	P mm	L mm	D2 mm	D4 mm	G mm	D5 mm	D6 mm	D7 mm	H mm	S1 mm	S2 mm	F1 mm	F2 mm	Breaking load N	Breaking load N*	Chain weight kg/m**
24000 lbf																	
ZC150	4	101,6	26	66,7	82	4	33	26,9	20,2	50	7	5	58	31,5	150.000	190.000	12
"	5	127	"	"	"	"	"	"	"	"	"	"	"	"	"	"	10,8
"	6	152,4	"	"	"	"	"	"	"	"	"	"	"	"	"	"	9,8
"	7	177,8	"	"	"	"	"	"	"	"	"	"	"	"	"	"	9
"	8	203,2	"	"	"	"	"	"	"	"	"	"	"	"	"	"	8,5
"	9	228,6	"	"	"	"	"	"	"	"	"	"	"	"	"	"	8,2
"	10	254	"	"	"	"	"	"	"	"	"	"	"	"	"	"	7,7
36000 lbf																	
ZC300	6	152,4	38	88,9	114	8,5	38	32	23,1	60	10	8	83	43,5	300.000	380.000	22,1
"	7	177,8	"	"	"	"	"	"	"	"	"	"	"	"	"	"	20
"	8	203,2	"	"	"	"	"	"	"	"	"	"	"	"	"	"	18,6
"	10	254	"	"	"	"	"	"	"	"	"	"	"	"	"	"	16,4
"	12	304,8	"	"	"	"	"	"	"	"	"	"	"	"	"	"	15,3

(*) Breaking load with heat treated plates

(**) Weight for chain with roller "Type C"

Additional features:

- metric pitch
- rollers of nylon, delrin, etc.
- in STAINLESS steel
- surface treatments of zinc plating, nickel plating, etc.
- pre-tensioned and labelled

BRITISH STANDARD CHAINS, BS 4116 PART 4

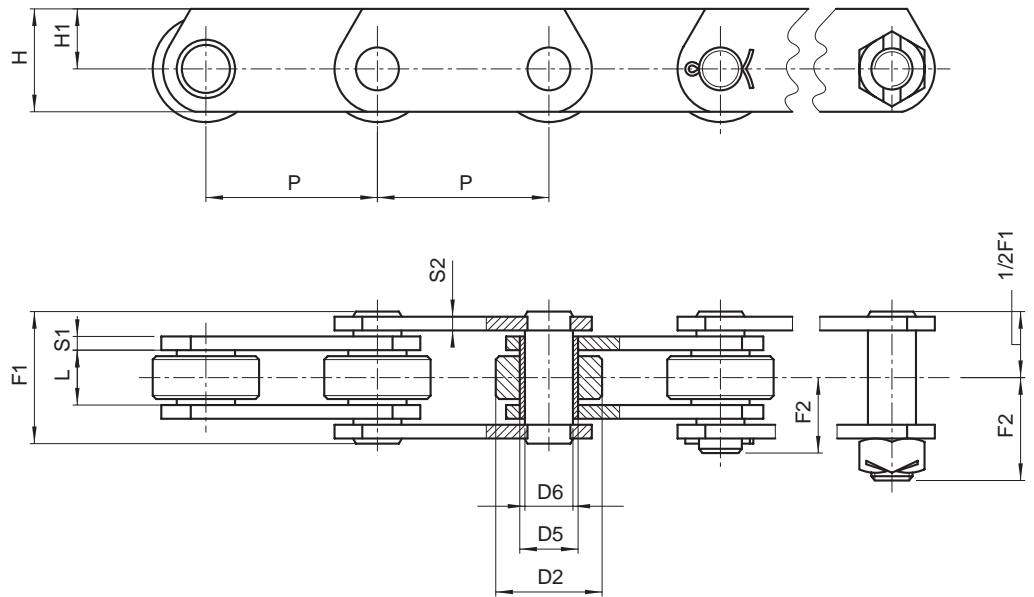

DEEP LINK CHAINS

Chain N.	P inches	P mm	L mm	D2 mm	D5 mm	D6 mm	H mm	H1 mm	S1 mm	S2 mm	F1 mm	F2 mm	F3 mm	Breaking load		Chain weight kg/m
														N	N*	
7500 lbf ZE40	2	50,8	15	31,75	17	14	40	27	4	4	37	22	28,5	40.000	60.000	5,6
"	2,5	63,5	"	"	"	"	"	"	"	"	"	"	"	"	"	5,1
"	3	76,2	"	"	"	"	"	"	"	"	"	"	"	"	"	4,4
"	3,5	88,9	"	"	"	"	"	"	"	"	"	"	"	"	"	4,1
"	4	101,6	"	"	"	"	"	"	"	"	"	"	"	"	"	3,9
"	5	127	"	"	"	"	"	"	"	"	"	"	"	"	"	3,6
"	6	152,4	"	"	"	"	"	"	"	"	"	"	"	"	"	3,3
15000 lbf ZE100	3	76,2	19	47,5	23	19	50	30	5	4	45	28	37	100.000	160.000	9,2
"	3,5	88,9	"	"	"	"	"	"	"	"	"	"	"	"	"	8,5
"	4	101,6	"	"	"	"	"	"	"	"	"	"	"	"	"	7,8
"	5	127	"	"	"	"	"	"	"	"	"	"	"	"	"	6,9
"	6	152,4	"	"	"	"	"	"	"	"	"	"	"	"	"	6,4
"	7	177,8	"	"	"	"	"	"	"	"	"	"	"	"	"	6
"	8	203,2	"	"	"	"	"	"	"	"	"	"	"	"	"	5,7

(*) Breaking load with heat treated plates

Additional features:

- metric pitch
- rollers of nylon, delrin, etc.
- in STAINLESS steel
- surface treatments of zinc plating, nickel plating, etc.
- pre-tensioned and labelled

BRITISH STANDARD CHAINS, BS 4116 PART 4

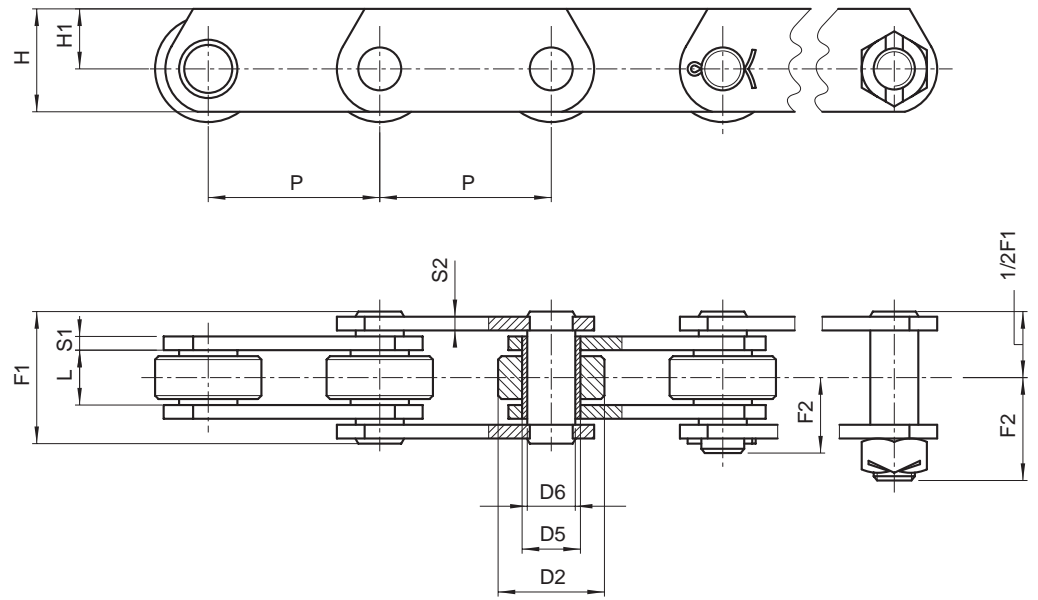

DEEP LINK CHAINS

Chain N.	P inches	P mm	L mm	D2 mm	D5 mm	D6 mm	H mm	H1 mm	S1 mm	S2 mm	F1 mm	F2 mm	F3 mm	Breaking load		Chain weight kg/m
														N	N*	
30000 lbf ZE160	4	101,6	26	66,7	33	26,9	70	45	7	5	58	34,5	51	160.000	200.000	17,6
"	5	127	"	"	"	"	"	"	"	"	"	"	"	"	"	15,4
"	6	152,4	"	"	"	"	"	"	"	"	"	"	"	"	"	13,9
"	7	177,8	"	"	"	"	"	"	"	"	"	"	"	"	"	12,9
"	8	203,2	"	"	"	"	"	"	"	"	"	"	"	"	"	12,1
"	9	228,6	"	"	"	"	"	"	"	"	"	"	"	"	"	11,5
"	10	254	"	"	"	"	"	"	"	"	"	"	"	"	"	11
60000 lbf ZE300	6	152,4	38	88,9	38	32	90	60	10	8	84	52	71	300.000	380.000	32,2
"	7	177,8	"	"	"	"	"	"	"	"	"	"	"	"	"	29,4
"	8	203,2	"	"	"	"	"	"	"	"	"	"	"	"	"	27,3
"	10	254	"	"	"	"	"	"	"	"	"	"	"	"	"	24,4
"	12	304,8	"	"	"	"	"	"	"	"	"	"	"	"	"	22,5

(*) Breaking load with heat treated plates

Additional features:

- metric pitch
- rollers of nylon, delrin, etc.
- in STAINLESS steel
- surface treatments of zinc plating, nickel plating, etc.
- pre-tensioned and labelled