

# REVOLEX® Flexible pin & bush coupling

## Technical data

REVOLEX® KX-D Technical data											
Size	Torque [Nm] NBR 80 Sha			Cast iron		Steel		Torsion spring stiffness C dyn. [Nm/rad]			
	Rated T <sub>KN</sub>	Max. T <sub>K max</sub>	Vibratory T <sub>KW</sub>	Max. speed [rpm] with v = 35 m/s	Max. bore [mm]	Max. speed [rpm] with v = 60 m/s	Max. bore [mm]	0.25 T <sub>KN</sub>	0.50 T <sub>KN</sub>	0.75 T <sub>KN</sub>	1.00 T <sub>KN</sub>
KX-D 75	4300	8600	1720	-	-	4500	100	6.73x10 <sup>5</sup>	1.04x10 <sup>6</sup>	1.54x10 <sup>6</sup>	2.17x10 <sup>6</sup>
KX-D 85	5500	11000	2200	-	-	4175	110	8.66x10 <sup>5</sup>	1.32x10 <sup>6</sup>	1.95x10 <sup>6</sup>	2.73x10 <sup>6</sup>
KX-D 95	7200	14400	2880	-	-	3845	125	1.11x10 <sup>6</sup>	1.70x10 <sup>6</sup>	2.49x10 <sup>6</sup>	3.47x10 <sup>6</sup>
KX-D 105	9400	18800	3760	2000	110	3475	130	1.45x10 <sup>6</sup>	2.21x10 <sup>6</sup>	3.23x10 <sup>6</sup>	4.51x10 <sup>6</sup>
KX-D 120	15200	30400	6080	1800	125	3100	150	1.78x10 <sup>6</sup>	2.48x10 <sup>6</sup>	3.54x10 <sup>6</sup>	4.85x10 <sup>6</sup>
KX-D 135	20000	40000	8000	1600	140	2725	170	2.34x10 <sup>6</sup>	3.27x10 <sup>6</sup>	4.65x10 <sup>6</sup>	6.36x10 <sup>6</sup>
KX-D 150	25000	50000	10000	1450	160	2500	190	2.94x10 <sup>6</sup>	4.12x10 <sup>6</sup>	5.87x10 <sup>6</sup>	8.06x10 <sup>6</sup>
KX-D 170	41000	82000	16400	1250	180	2150	220	4.36x10 <sup>6</sup>	7.91x10 <sup>6</sup>	1.14x10 <sup>7</sup>	1.50x10 <sup>7</sup>
KX-D 190	54000	108000	21600	1100	205	1900	245	5.78x10 <sup>6</sup>	1.05x10 <sup>7</sup>	1.52x10 <sup>7</sup>	1.98x10 <sup>7</sup>
KX-D 215	67500	135000	27000	1000	230	1725	275	7.21x10 <sup>6</sup>	1.30x10 <sup>7</sup>	1.89x10 <sup>7</sup>	2.47x10 <sup>7</sup>
KX-D 240	98000	196000	39200	900	250	1550	310	1.19x10 <sup>7</sup>	2.52x10 <sup>7</sup>	3.84x10 <sup>7</sup>	5.17x10 <sup>7</sup>
KX-D 265	134000	268000	53600	800	285	1375	350	1.62x10 <sup>7</sup>	3.44x10 <sup>7</sup>	5.26x10 <sup>7</sup>	7.07x10 <sup>7</sup>
KX-D 280	170000	340000	68000	720	315	1225	385	2.05x10 <sup>7</sup>	4.36x10 <sup>7</sup>	6.66x10 <sup>7</sup>	8.97x10 <sup>7</sup>
KX-D 305	205000	410000	82000	675	330	1150	405	2.49x10 <sup>7</sup>	5.27x10 <sup>7</sup>	8.05x10 <sup>7</sup>	1.08x10 <sup>8</sup>
KX-D 330	265000	530000	106000	625	355	1075	435	3.20x10 <sup>7</sup>	6.78x10 <sup>7</sup>	1.04x10 <sup>8</sup>	1.40x10 <sup>8</sup>
KX-D 355	350000	700000	140000	575	380	975	450	4.26x10 <sup>7</sup>	8.99x10 <sup>7</sup>	1.37x10 <sup>8</sup>	1.85x10 <sup>8</sup>
KX-D 370	430000	860000	172000	535	450	900	530	4.92x10 <sup>7</sup>	1.04x10 <sup>8</sup>	1.59x10 <sup>8</sup>	2.14x10 <sup>8</sup>
KX-D 470	520000	1040000	208000	-	-	855	520	6.25x10 <sup>7</sup>	1.33x10 <sup>8</sup>	2.03x10 <sup>8</sup>	2.74x10 <sup>8</sup>
KX-D 520	810000	1620000	324000	-	-	740	According to customer specification	9.83x10 <sup>7</sup>	2.08x10 <sup>8</sup>	3.18x10 <sup>8</sup>	4.28x10 <sup>8</sup>
KX-D 590	1000000	2000000	400000	-	-	660	According to customer specification	1.21x10 <sup>8</sup>	2.56x10 <sup>8</sup>	3.91x10 <sup>8</sup>	5.26x10 <sup>8</sup>
KX-D 650	1350000	2700000	540000	-	-	590	According to customer specification	1.63x10 <sup>8</sup>	3.47x10 <sup>8</sup>	5.30x10 <sup>8</sup>	7.14x10 <sup>8</sup>

■ = Years of experience with applications at customer sites and additional test series in the KTR test field in Rheine enabled us to determine potentials allowing for an increase of the rated and maximum torques with some sizes of this series.

If requested, coupling is dynamically balanced (semi-key balancing G 6.3 with speed on request of customer). For circumferential speeds exceeding v = 30 m/s dyn. balancing is recommended.

Axial displacement  $\Delta K_a$

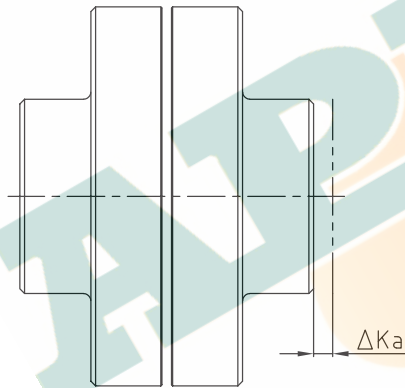

$$L_{\max./\min.} = L + \Delta K_a \text{ [mm]}$$

Radial displacement  $\Delta K_r$

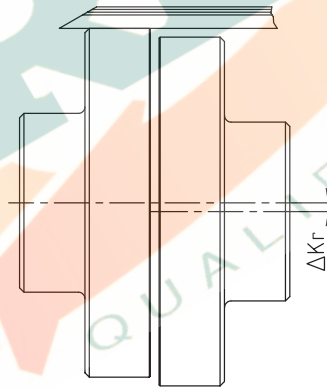

Angular displacement  $\Delta K_w$

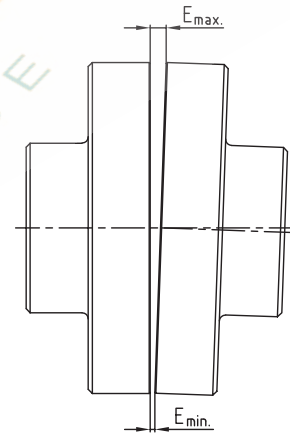

$$\Delta K_w = E_{\max.} - E_{\min.} \text{ [mm]}$$

Displacements																						
Size (KX and KX-D)		75	85	95	105	120	135	150	170	190	215	240	265	280	305	330	355	370	470	520	590	650
Max. axial displacement $\Delta K_a$ [mm]		±1.5	±1.5	±1.5	±2	±2	±2	±2	±2.5	±2.5	±2.5	±2.5	±2.5	±2.5	±2.5	±4	±4	±4	±4	±4	±4	±4
Max. radial displacement $\Delta K_r$ [mm] or max. angular displacement $\Delta K_w$ [mm] with speed n	250 rpm	0.95	1.1	1.1	1.2	1.3	1.4	1.5	1.7	1.9	2.0	2.2	2.5	2.7	2.9	3.1	3.3	3.5	3.8	4.4	4.9	5.4
	500 rpm	0.70	0.80	0.80	0.9	0.9	1.0	1.1	1.2	1.3	1.4	1.6	1.7	1.9	2.0	2.2	2.3	2.5	2.8	3.1	3.5	3.8
	750 rpm	0.60	0.65	0.65	0.7	0.8	0.8	0.9	1.0	1.1	1.2	1.3	1.4	1.6	1.7	1.8	1.9	2.0	2.2	2.4	-	-
	1000 rpm	0.50	0.55	0.55	0.6	0.7	0.7	0.8	0.9	0.9	1.0	1.1	1.2	1.4	1.4	1.5	1.7	1.8	-	-	-	-
	1500 rpm	0.40	0.45	0.45	0.5	0.5	0.6	0.6	0.7	0.8	0.8	0.9	1.0	-	-	-	-	-	-	-	-	-
	2000 rpm	0.35	0.40	0.40	0.4	0.5	0.5	0.5	0.6	0.7	-	-	-	-	-	-	-	-	-	-	-	-
3000 rpm	0.30	0.35	0.35	0.4	0.4	-	-	-	-	-	-	-	-	-	-	-	-	-	-	-	-	

### Advice for assembly

The permissible displacement figures of the flexible REVOLEX® KX couplings specified are general standard values taking into account the load of the coupling up to the rated torque T<sub>KN</sub> of the coupling and an ambient temperature of +30 °C. The displacement figures may only be used one by one - if they appear simultaneously, they must be limited in proportion. Care should be taken to maintain the distance dimension E accurately in order to allow for axial clearance of the coupling while in operation. See KTR assembly instructions, KTR standard 49410 at our homepage www.ktr.com.

# REVOLEX® KX-D

## Flexible pin & bush coupling

### Material cast

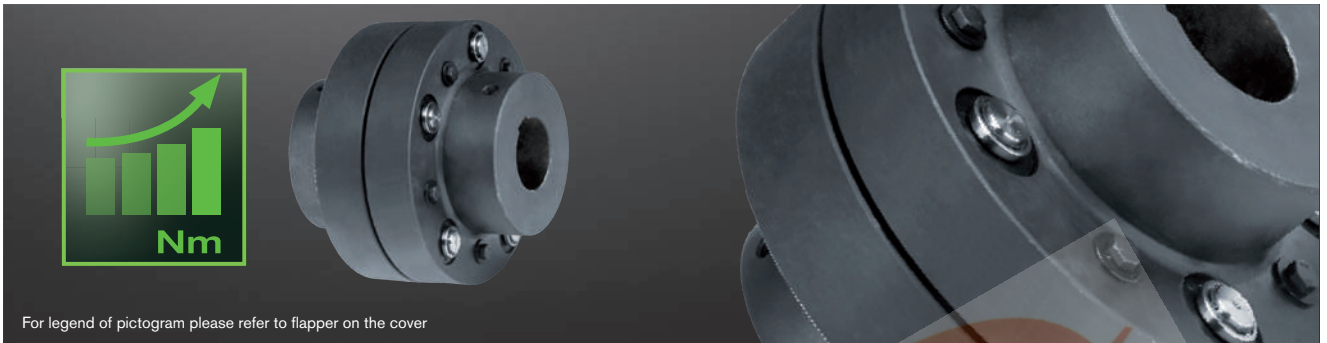

For legend of pictogram please refer to flapper on the cover



### Components

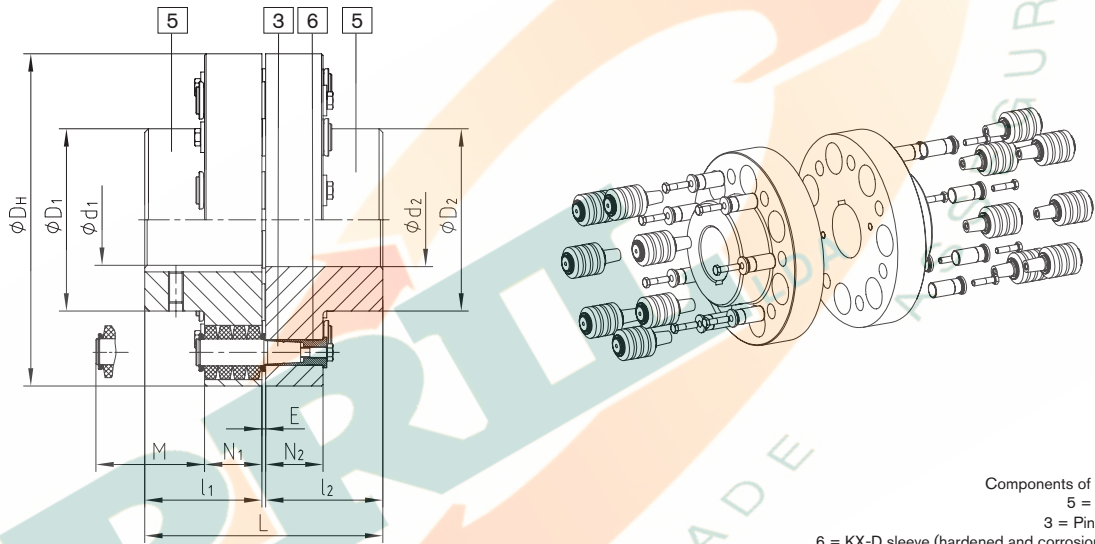

Components of type KX-D:  
 5 = Hub part 5  
 3 = Pins complete  
 6 = KX-D sleeve (hardened and corrosion-resistant)

REVOLEX® Type KX-D													
Size	Torque <sup>1)</sup> [Nm]		Max. speed <sup>2)</sup> [rpm]	Finish bore (min. - max.) d <sub>1</sub> , d <sub>2</sub>	Dimensions [mm]							Mass moment of inertia <sup>3)</sup> [kgm <sup>2</sup> ]	Weight <sup>3)</sup> [kg]
	T <sub>KN</sub>	T <sub>Kmax.</sub>			L	l <sub>1</sub> , l <sub>2</sub>	E	D <sub>H</sub>	D <sub>1</sub> , D <sub>2</sub>	N <sub>1</sub> , N <sub>2</sub>	M*		
KX-D 105	9400	18800	2000	38-110	237	117	3	330	180	56	76	0.907	68
KX-D 120	15200	30400	1800	45-125	270	132	6	370	206	76	100	1.867	108
KX-D 135	20000	40000	1600	75-140	300	147	6	419	230	76	100	3.144	145
KX-D 150	25000	50000	1450	85-160	336	165	6	457	256	76	100	4.573	180
KX-D 170	41000	82000	1250	95-180	382	188	6	533	292	92	130	10.259	291
KX-D 190	54000	108000	1100	110-205	428	211	6	597	330	92	130	16.601	385
KX-D 215	67500	135000	1000	125-230	480	237	6	660	368	92	130	25.495	498
KX-D 240	98000	196000	900	140-250	534	264	6	737	407	122	170	50.147	760
KX-D 265	134000	268000	800	160-285	590	292	6	826	457	122	170	80.796	997
KX-D 280	170000	340000	720	180-315	628	311	6	927	508	122	170	129.979	1301
KX-D 305	205000	410000	675	180-330	654	324	6	991	533	122	170	170.016	1509
KX-D 330	265000	530000	625	200-355	666	330	6	1067	572	122	170	227.451	1755
KX-D 355	350000	700000	575	225-380	721	356	9	1156	610	164	220	415.259	2263
KX-D 370	430000	860000	535	225-450	773	382	9	1250	720	164	220	586.686	2701

■ = Years of experience with applications at customer sites and additional test series in the KTR test field in Rheine enabled us to determine potentials allowing for an increase of the rated and maximum torques with some sizes of this series.

\* Drop-out center dimension required

<sup>1)</sup> Standard material Perbunan [NBR] 80 Shore A, for selection see page 18 et seqq.

<sup>2)</sup> Higher speeds on request.

<sup>3)</sup> Referring to max. bore

Finish bore according to ISO fit H7, feather keyway according to DIN 6885, sheet 1 [JS9].

If requested, coupling is dynamically balanced (semi-key balancing G 6.3 with speed on request of customer). For circumferential speeds exceeding v = 30 m/s dyn. balancing is recommended.

■ = Pilot bored available from stock

<b>Ordering example:</b>	REVOLEX® KX-D 170	GJL	Ø120	Ø150
	Type and size of coupling	Material	Finish bore	Finish bore

# REVOLEX® KX-D

## Flexible pin & bush coupling

Flexible jaw and pin & bush couplings

Material steel

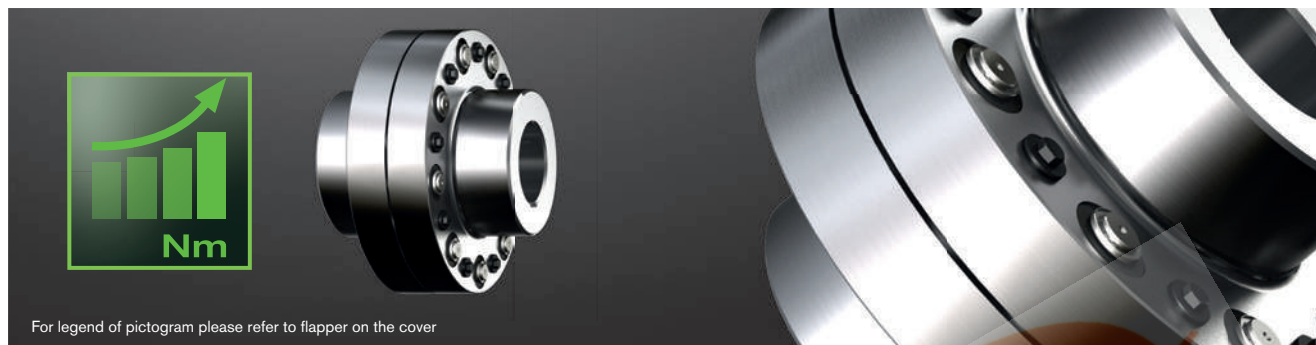

ROTEX®



### Components

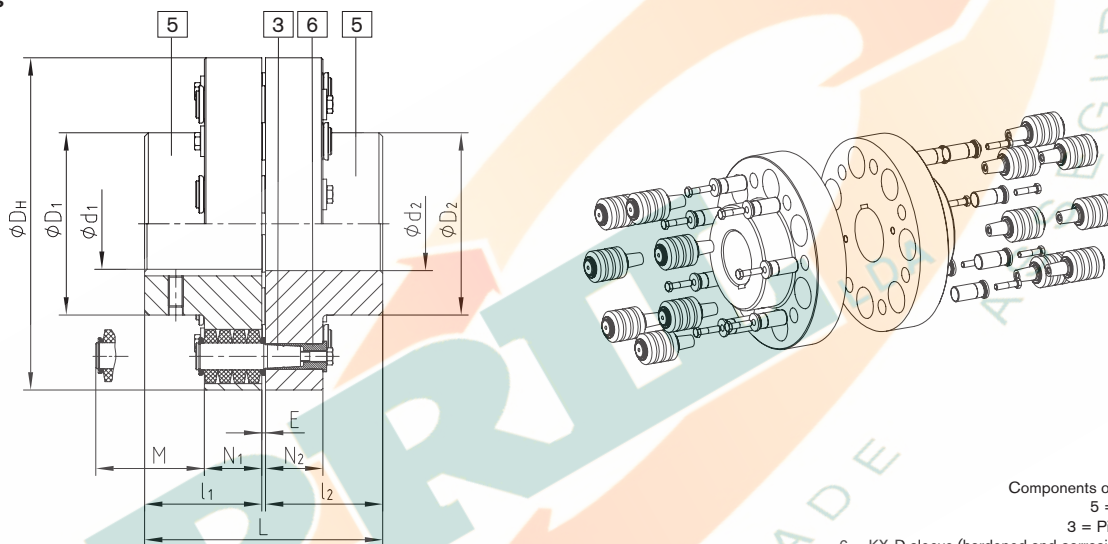

Components of type KX-D:  
5 = Hub part 5  
3 = Pins complete  
6 = KX-D sleeve (hardened and corrosion-resistant)

POLY-NORM®

### REVOLEX® Type KX-D

Size	Torque <sup>1)</sup> [Nm]		Max. speed <sup>2)</sup> [rpm]	Finish bore (min. - max.) d <sub>1</sub> , d <sub>2</sub>	Dimensions [mm]							Mass moment of inertia <sup>3)</sup> [kgm <sup>2</sup> ]	Weight <sup>3)</sup> [kg]
	T <sub>KN</sub>	T <sub>Kmax.</sub>			L	l <sub>1</sub> , l <sub>2</sub>	E	D <sub>H</sub>	D <sub>1</sub> , D <sub>2</sub>	N <sub>1</sub> , N <sub>2</sub>	M*		
KX-D 75	4300	8600	4500	0-100	193	95	3	255	136	56	76	0.325	39
KX-D 85	5500	11000	4175	0-110	213	105	3	274	152	56	76	0.440	46
KX-D 95	7200	14400	3825	0-125	227	112	3	298	168	56	76	0.624	56
KX-D 105	9400	18800	3475	0-130	237	117	3	330	180	56	76	0.907	80
KX-D 120	15200	30400	3100	0-150	270	132	6	370	206	76	100	1.867	124
KX-D 135	20000	40000	2725	75-170	300	147	6	419	230	76	100	3.144	165
KX-D 150	25000	50000	2500	85-190	336	165	6	457	256	76	100	4.573	205
KX-D 170	41000	82000	2150	95-220	382	188	6	533	292	92	130	10.259	322
KX-D 190	54000	108000	1900	110-245	428	211	6	597	330	92	130	16.601	431
KX-D 215	67500	135000	1725	125-275	480	237	6	660	368	92	130	25.495	559
KX-D 240	98000	196000	1550	140-310	534	264	6	737	407	122	170	50.147	833
KX-D 265	134000	268000	1375	160-350	590	292	6	826	457	122	170	80.796	1099
KX-D 280	170000	340000	1225	180-385	628	311	6	927	508	122	170	129.979	1436
KX-D 305	205000	410000	1150	180-405	654	324	6	991	533	122	170	170.016	1669
KX-D 330	265000	530000	1075	200-435	666	330	6	1067	572	122	170	227.451	1954
KX-D 355	350000	700000	975	225-450	721	356	9	1156	610	164	220	415.259	2451
KX-D 370	430000	860000	900	225-530	773	382	9	1250	720	164	220	584.686	2925
KX-D 470	520000	1040000	855	240-520 <sup>4)</sup>	969 <sup>4)</sup>	480 <sup>4)</sup>	9	1340	705 <sup>4)</sup>	164	220	785.489	3631
KX-D 520	810000	1620000	760	240-520 <sup>4)</sup>	1089 <sup>4)</sup>	540 <sup>4)</sup>	9	1540	780 <sup>4)</sup>	164	220	1264.725	5155
KX-D 590	1000000	2000000	680	260-590 <sup>4)</sup>	1212 <sup>4)</sup>	600 <sup>4)</sup>	12	1735	885 <sup>4)</sup>	164	220	2081.885	6895
KX-D 650	1350000	2700000	610	280-650 <sup>4)</sup>	1332 <sup>4)</sup>	660 <sup>4)</sup>	12	1935	975 <sup>4)</sup>	164	220	3228.297	8893

■ = Years of experience with applications at customer sites and additional test series in the KTR test field in Rheine enabled us to determine potentials allowing for an increase of the rated and maximum torques with some sizes of this series.

\* Drop-out center dimension required <sup>1)</sup> Standard material Perbunan [NBR] 80 Shore A, for selection see page 18 et seq.

<sup>2)</sup> Higher speeds on request. <sup>3)</sup> Referring to max. bore <sup>4)</sup> Variable according to customer's requests

Finish bore according to ISO fit H7, feather keyway according to DIN 6885, sheet 1 [JS9]. If requested, coupling is dynamically balanced (semi-key balancing G 6.3 with speed on request of customer). For circumferential speeds exceeding  $v = 30$  m/s dyn. balancing is recommended.

■ = Pilot bored available from stock

Ordering example:

REVOLEX® KX-D 170	Steel	Ø120	Ø150
Type and size of coupling	Material	Finish bore	Finish bore

POLY

REVOLEX®

# REVOLEX® KX-D SB

## Flexible pin & bush coupling

### With brake disk

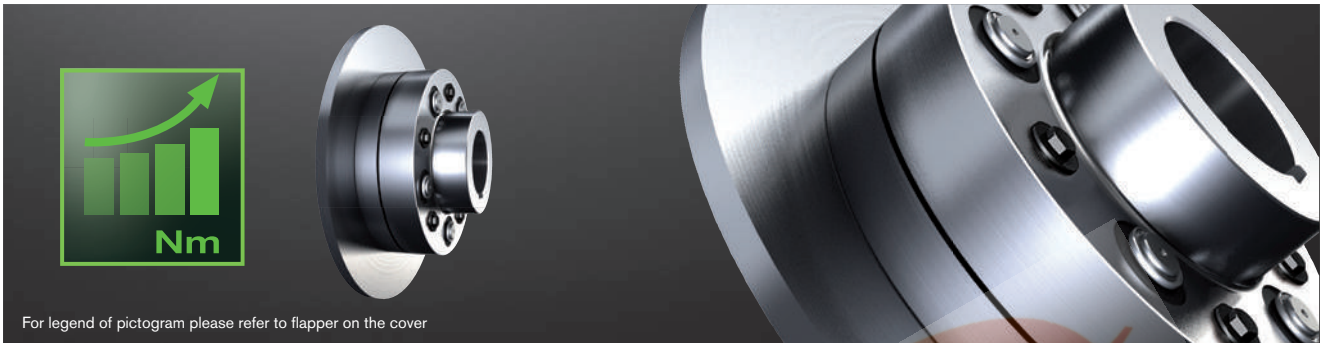

For legend of pictogram please refer to flapper on the cover



#### REVOLEX® KX-D Type SB

Size	Torque <sup>1)</sup> [Nm] KX-D		Finish bore KX-D (min. - max.)		Dimensions [mm]								
	T <sub>KN</sub>	T <sub>K max</sub>	GJL d <sub>1</sub> , d <sub>2</sub>	Steel d <sub>1</sub> , d <sub>2</sub>	L	l <sub>1</sub> , l <sub>2</sub>	E	D <sub>H</sub>	D <sub>1</sub>	N <sub>1</sub>	N <sub>2</sub>	N <sub>3</sub>	M*
105	9400	18800	34-110	0-130	237	117	3	330	180	56	29	55	76
120	15200	30400	50-125	0-150	270	132	6	370	206	76	45	75	100
135	20000	40000	70-140	70-170	300	147	6	419	230	76	45	75	100
150	25000	50000	82-160	82-190	336	165	6	457	256	76	45	75	100
170	41000	82000	95-180	95-220	382	188	6	533	292	92	62	91	130
190	54000	108000	110-205	110-245	428	211	6	597	330	92	62	91	130
215	67500	135000	125-230	125-275	480	237	6	660	368	92	62	91	145
240	98000	196000	140-250	140-310	534	264	6	737	407	122	75	121	167

**■** = Years of experience with applications at customer sites and additional test series in the KTR test field in Rheine enabled us to determine potentials allowing for an increase of the rated and maximum torques with some sizes of this series.

#### Selection of coupling/brake disk dimension N

Size	Brake disk ØA x b <sup>2)</sup>					
	Ø560x30	Ø630x30	Ø710x30	Ø800x30	Ø900x30	Ø1000x30
	KX-D	KX-D	KX-D	KX-D	KX-D	KX-D
105	47	47				
120	42	42				
135		57	57			
150			75	75		
170			82	82		
190				105	105	
215				131	131	131
240				128	128	128

\* Drop-out center dimension required

<sup>1)</sup> Standard material Perbunan [NBR] 80 Shore A, for selection see page 18 et seqq.

<sup>2)</sup> Maximum circumferential speed v = 60 m/s referring to the maximum outside diameter.

Finish bore according to ISO fit H7, feather keyway according to DIN 6885, sheet 1 [JS9].

If requested, coupling is dynamically balanced (semi-key balancing G 6.3 with speed on request of customer). For circumferential speeds exceeding v = 30 m/s dynamic balancing is necessary (referring to outside diameter ØA).

#### Ordering example:

REVOLEX® KX 170	SB	Ø710 x 30	1 - Ø120	2SB - Ø150
Type and size of coupling	Type	Brake disk	Finish bore	Finish bore

Components

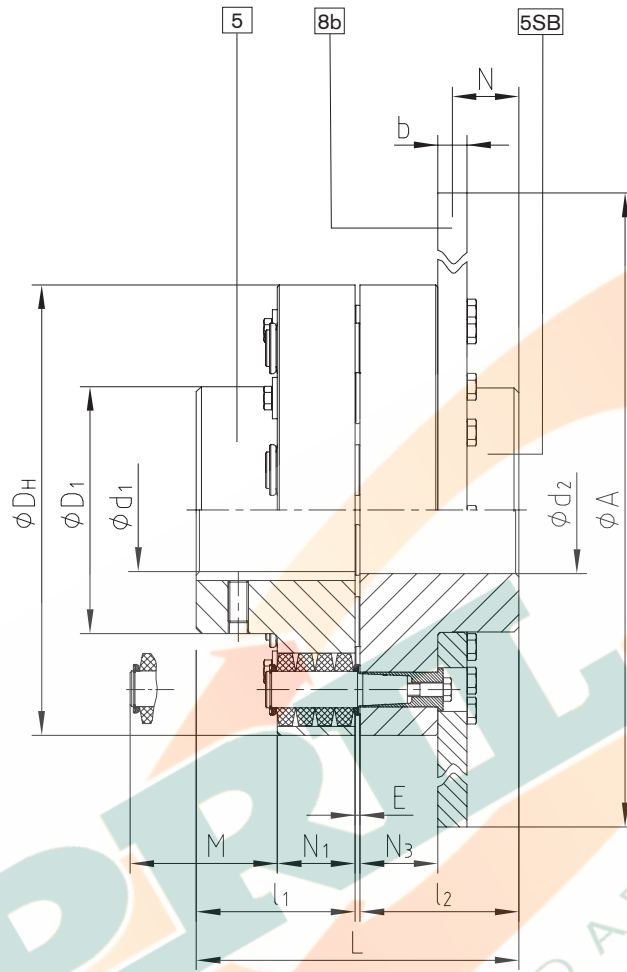

ROTEX®

POLY-NORM®

POLY

REVOLLEX®

Flexible jaw and pin & bush couplings



# REVOLEX® KX-D with KTR 650 clamping set

## Flexible pin & bush coupling

### Material steel

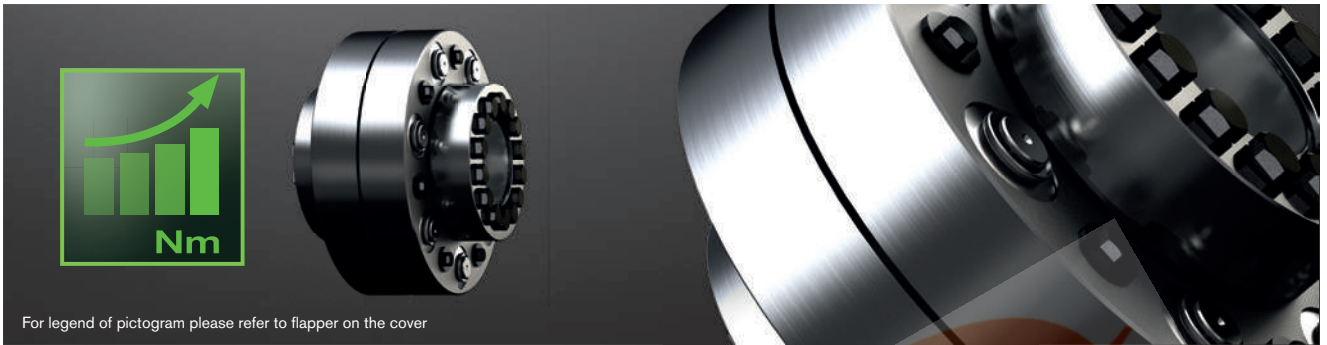

For legend of pictogram please refer to flapper on the cover

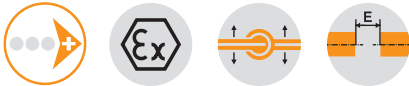

REVOLEX® KX-D						CLAMPEX® KTR 650						
Size	D <sub>H</sub>	L <sub>1</sub> /L <sub>2</sub>	N	E	T <sub>KN</sub> <sup>1)</sup> [Nm]	Dimensions [mm]		Screws				Transmittable torque T [Nm]
						Max. perm. size d x D	T <sub>K</sub>	Size	Length	Quantity	T <sub>A</sub> [Nm]	
105	330	123	56	3	9400	100 x 197	156	M16	75	14	250	18800
120	370	149	76	6	15200	110 x 215	166	M20	90	10	490	22400
135	419	157	76	6	20000	120 x 230	186	M20	90	14	490	35200
150	457	168	76	6	25000	140 x 290	216	M20	100	16	490	46700
170	533	205	92	6	41000	180 x 340	276	M24	130	16	840	85800
190	597	214	92	6	54000	220 x 405	320	M27	140	18	1250	148600
215	660	232	92	6	67500	260 x 460	356	M27	160	21	1250	192900
240	737	254	122	6	98000	240 x 430	340	M27	150	20	1250	175400
265	826	280	122	6	134000	320 x 550	402	M27	180	24	1250	248900
280	927	313	122	6	170000	390 x 630	486	M30	200	24	1700	368300
305	991	321	122	6	205000	440 x 700	534	M30	220	28	1700	472100
330	1067	321	122	6	265000	440 x 700	534	M30	220	28	1700	472100

  = Years of experience with applications at customer sites and additional test series in the KTR test field in Rheine enabled us to determine potentials allowing for an increase of the rated and maximum torques with some sizes of this series.

<sup>1)</sup> Standard material Perbunan [NBR] 80 Shore A, for selection see page 18 et seqq.

If requested, coupling is dynamically balanced (semi-key balancing G 6.3 with speed on request of customer). For circumferential speeds exceeding  $v = 30$  m/s dynamic balancing is necessary (referring to outside diameter ØA).

CLAMPEX® KTR 650							
d x D	Dimensions [mm]		Screws				Transmittable
	B1/B2	T <sub>K</sub>	Size	Length	Quantity	T <sub>A</sub> [Nm]	
100 x 215	73	166	M20	90	10	490	22400
110 x 230	81	186	M20	90	14	490	33600
120 x 290	92	216	M20	100	16	490	42100
130 x 290	92	216	M20	100	16	490	46700
140 x 320	102	234	M24	110	14	840	63600
150 x 320	102	234	M24	110	14	840	63600
160 x 340	113	276	M24	130	16	840	85800
170 x 340	113	276	M24	130	16	840	85800
180 x 370	117	290	M27	140	16	1,250	119700
190 x 370	117	290	M27	140	16	1,250	119700
200 x 405	122	320	M27	140	18	1,250	148600
210 x 405	122	320	M27	140	18	1,250	148600
220 x 430	132	340	M27	150	20	1,250	175400
230 x 430	132	340	M27	150	20	1,250	175400
240 x 460	140	356	M27	160	21	1,250	192900
250 x 460	140	356	M27	160	21	1,250	192900
260 x 485	147	360	M27	180	21	1,250	195000
270 x 485	147	360	M27	180	21	1,250	195000
280 x 520	150	380	M27	180	21	1,250	205900
290 x 520	150	380	M27	180	21	1,250	205900
300 x 550	158	402	M27	180	24	1,250	248900
310 x 550	158	402	M27	180	24	1,250	248900
320 x 570	164	424	M27	180	24	1,250	262500
330 x 570	164	424	M27	180	24	1,250	262500
340 x 610	171	454	M30	190	24	1,700	344000
350 x 610	171	454	M30	190	24	1,700	344000

<b>Ordering example:</b>	REVOLEX® KX-D 170	Steel	KTR 650 Ø120	KTR 650 Ø150
	Type and size of coupling	Material	KTR 650 for shaft diameter	KTR 650 for shaft diameter

Components

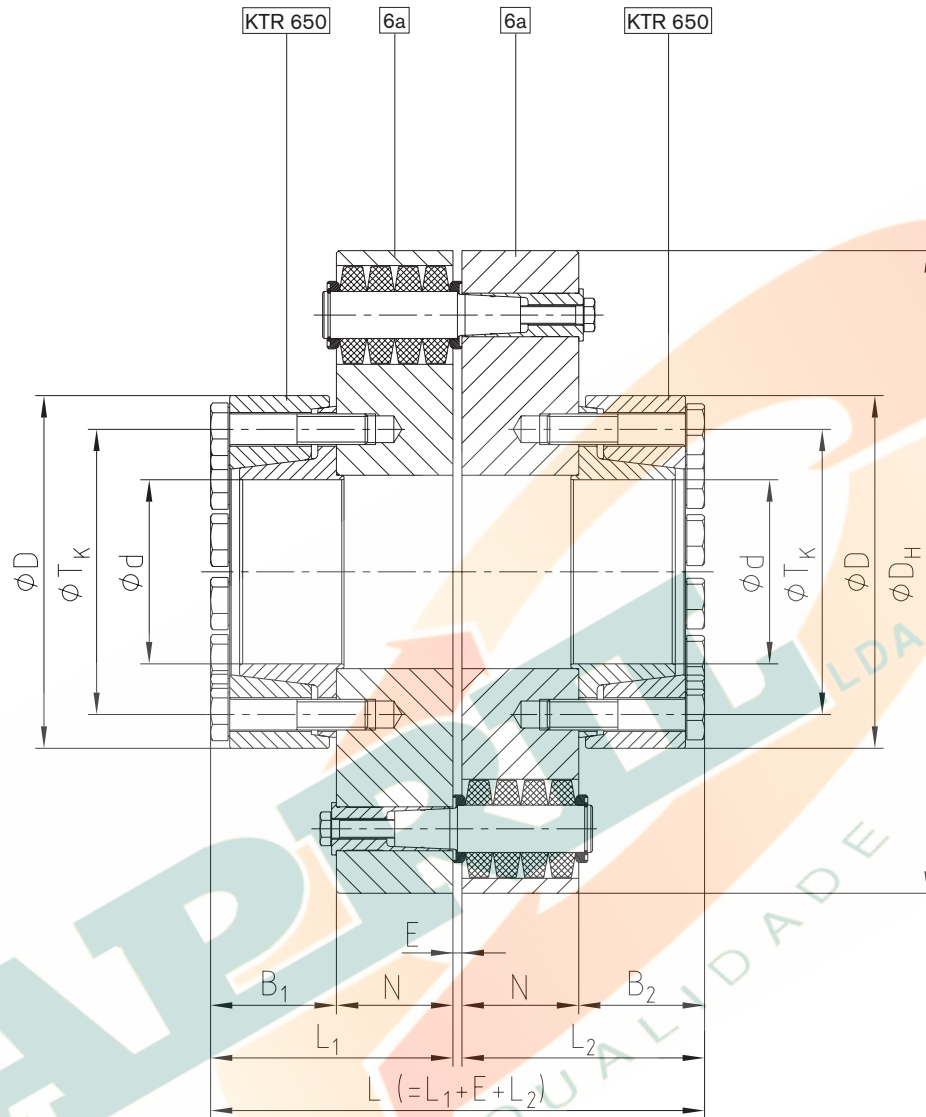

ROTEX®

POLY-NORM®

POLY

REVOLEX®

# REVOLEX® KX-D

## Flexible pin & bush coupling

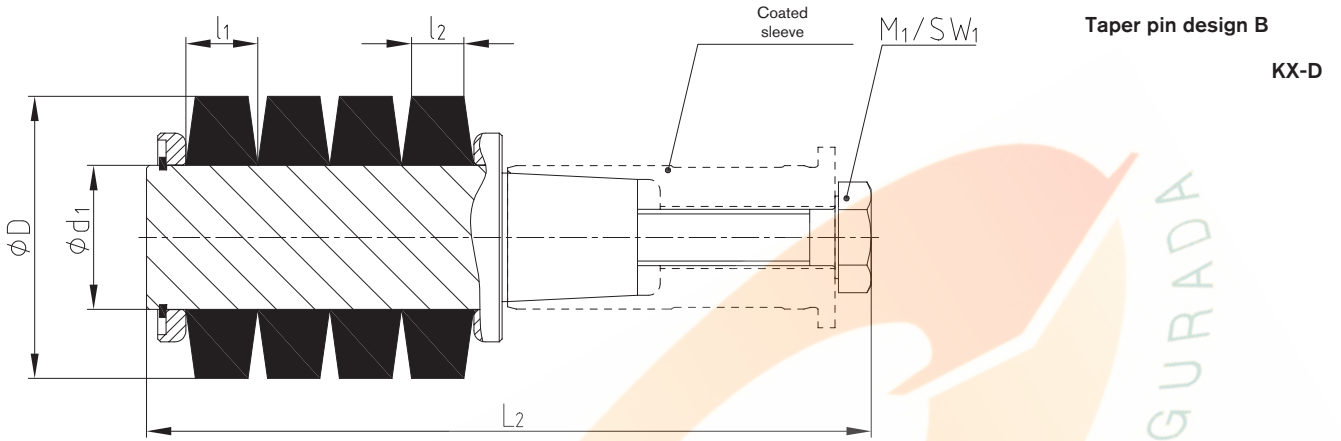

### Technical data of pins



#### Technical data

Size	Pin		Component 3.2			Component 3.1b			Component 3.4b		Tightening torque $T_A$ [Nm]
	Size	Quantity	Elastomer ring NBR 80 Shore A			Pin			Screw DIN EN ISO 4014/4017		
	KX-D		D	$l_1$	$l_2$	$d_1$	$L_1$	$L_2$	$M_1$	$SW_1$	
75	3	10									
85	3	12									
95	3	14	50.0	12.7	9.0	25.40	103	129	M10	17	67
105	3	16									
120	4	14									
135	4	16	63.0	17.8	12.5	30.60	147.5	178	M12	19	115
150	4	18									
170	5	14									
190	5	16	85.5	22.9	15.2	43.20	191	220	M16	24	290
215	5	18									
240	6	14									
265	6	16									
280	6	18	113.7	30.5	20.3	58.40	244	290	M24	36	970
305	6	20									
330	6	24									
355	7	16									
370	7	20	150	41	28	75	-	387	M30	46	1950
470	7	22									

#### General information on the elastomer rings

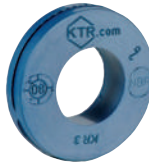
	Perbunan [NBR]	Natural rubber [NR]	Perbunan [NBR]
Material	Perbunan [NBR]	Natural rubber [NR]	Perbunan [NBR]
Hardness	80 Shore A	80 Shore A	80 Shore A
Permanent temperature range [°C]	-30 to +80	-50 to +70	-30 to +80
Max. temperature (short time) [°C]	-50 to +120	-	-
Colour	black	black	blue
Operating range	STANDARD	sub-zero temperatures	electrically insulating and backlash-free, e. g. cableway drives
			



Assembly/disassembly

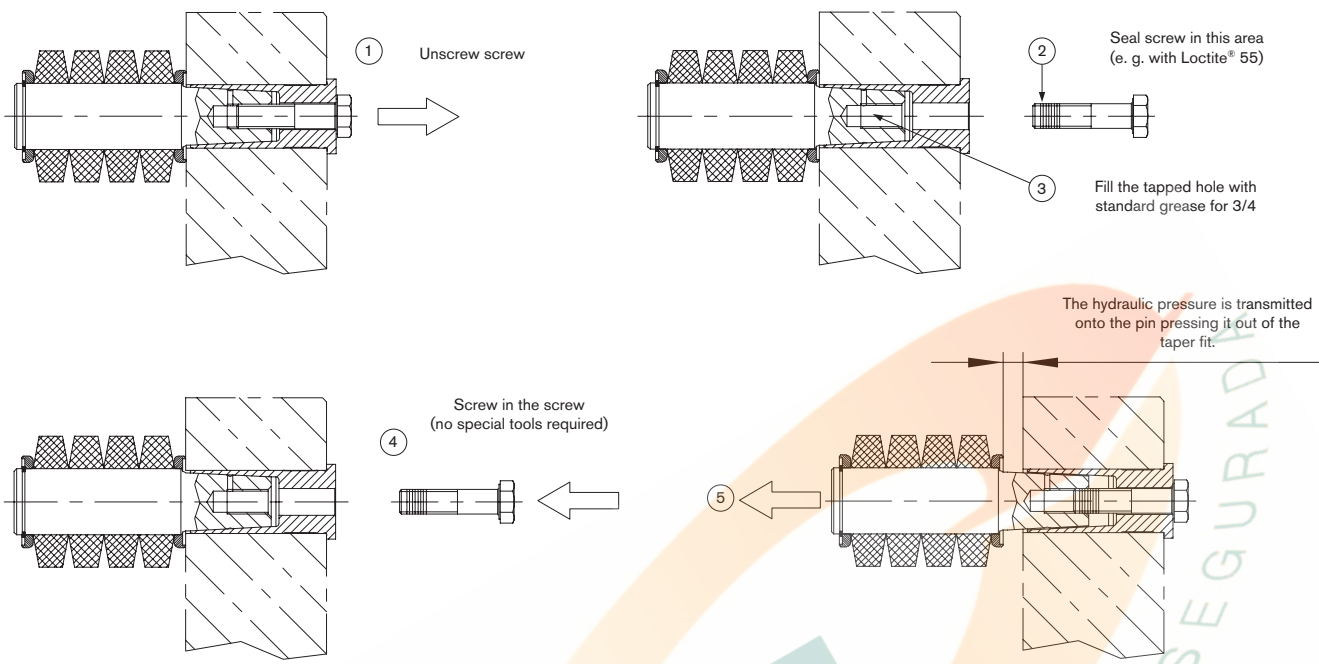

Other types

Type AB with limitation of axial backlash

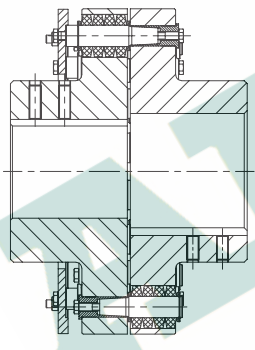

Intermediate shaft type with RADEX®-N

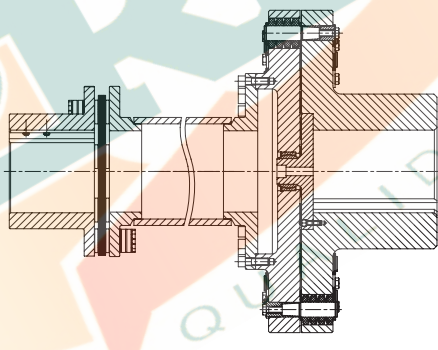

Backlash-free type

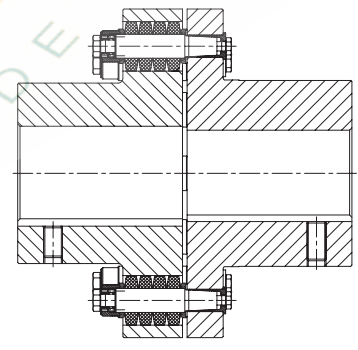

Type KX-D SD shiftable with shiftable linkage

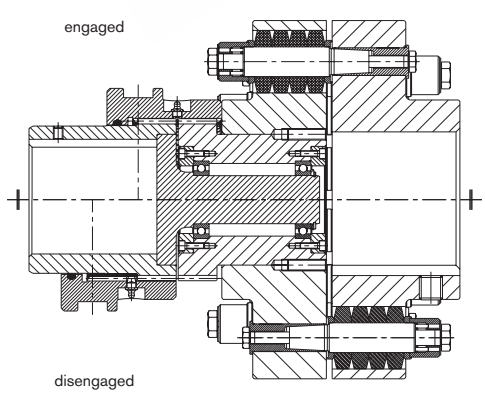

Type KX-D with cardan shaft connection

