



SPEED VARIATORS CHV SERIES



SPEED VARIATORS CHV SERIES

Chiaravalli Group S.p.A. introduces his mechanical speed variators line with oil bath lubrication CHV series sizes 02-05-10-20-30-50, the main characteristics are the following:

- Speed range 1:5
- Smooth and silent running
- Increasing torque at low speed
- High efficiency
- Input and output flange B5
- Compact design
- Aluminium cases sizes 02-05-10
- RAL 9022 grey painted



DESIGNATION

TYPE	SIZE	POWER Kw	POLES	VOLTAGE	FREQUENCY	T.BOX POS.	MOUNT. POS.
CHV	02	0.18 - 0.22	4	230/400	50HZ	1	B5
	05	0.37				2	V1
	10	0.75				3	V3
	20	1.1 - 1.5				4	
	30	2.2					
	50	3.0 - 4.0					

Mounting position

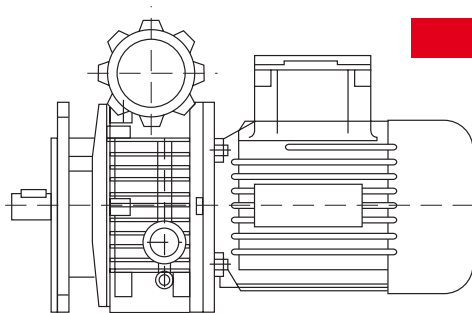

B5

Terminal box position

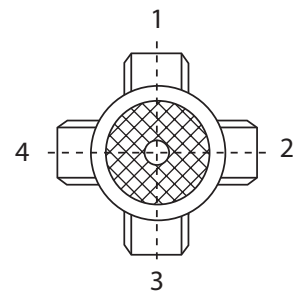

V1

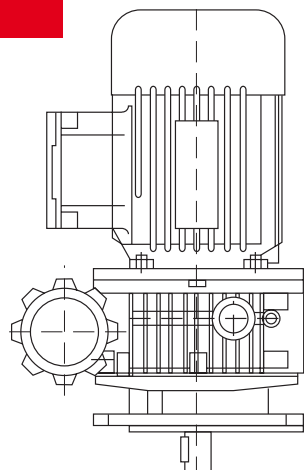

V3

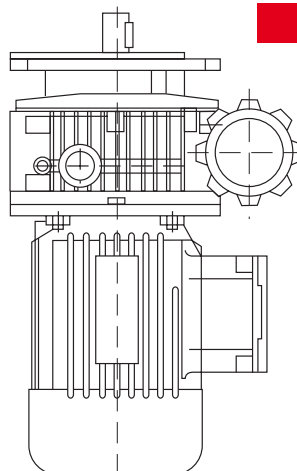



PERFORMANCES WITH 4 POLES MOTORS

SPEED VARIATOR	POWER Kw	OUTPUT SPEED	OUTPUT TORQUE Nm
CHV 02	0.18	170 - 880	3.0 - 1.5
CHV 02	0.22	170 - 880	3.8 - 1.9
CHV 05	0.37	200 - 1000	6.0 - 3.0
CHV 10	0.75	200 - 1000	12 - 6.0
CHV 20	1.10	200 - 1000	18 - 9.0
CHV 20	1.50	200 - 1000	24 - 12
CHV 30	2.20	200 - 1000	36 - 18
CHV 50	3.00	200 - 1000	48 - 24
CHV 50	4.00	200 - 1000	64 - 32



LUBRICATION

Speed variators are supplied with lubrication oil for assembly position B5, for other positions it will be necessary to add oil, see following table.

OIL QUANTITY Kg						
CHV	02	05	10	20	30	50
B5	0.13	0.15	0.33	0.8	1.20	1.20
V1	0.3	0.4	0.85	1.40	2.15	2.15
V3	0.2	0.25	0.45	0.90	1.30	1.30



RECOMMENDED OILS

AGIP	A.T.F. DEXRON
ESSO	A.T.F. DEXRON
SHELL	A.T.F. DEXRON
BP	A.T.F. DEXRON



CHV 02/05/10/20/30/50 DIMENSIONS

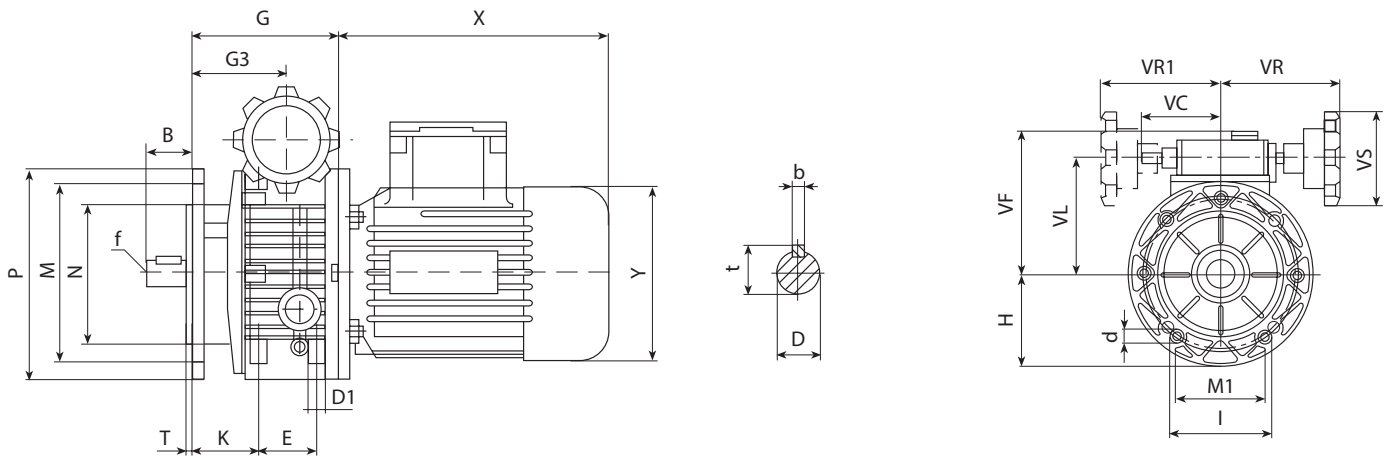

	B	D(j6)	E	G	G3	H	I	M	M1	N	d	D1	P	T	K	VC	VF	VL	VR	VR1	VS	b	f	t	kg
CHV 02	23	11	50	112.5	64.5	70	72	115	60	95	9	M6	140	3.5	46	71	111	78	110	110	85	4	M5	12.5	3.4
CHV 05	30	14	40	110	74	80	90	130	76	110	9	M8	160	3.5	52.5	71	123	90	110	110	85	5	M6	16	4.7
CHV 10	40	19	58	139	85.5	100	98	165	84	130	11	M8	200	3.5	60	79	140	107	120	120	110	6	M6	21.5	7.8
CHV 20	50	24	-	188	115	126	241	165	-	130	11	-	200	3.5	-	-	144	122	150	-	110	8	M8	27	31
CHV 30	60	28	-	222	131	150	270	215	-	180	15	-	250	4	-	-	188	150	160	-	110	8	M10	33	55
CHV 50	60	28	-	222	131	150	270	215	-	180	15	-	250	4	-	-	188	150	160	-	110	8	M10	33	57



ACCESSORIES

Gravitational indicator

The gravitational indicator must be inserted into the handwheel and with a numerical scale it shows a reference link to the speed. Set the indicator moving the two hands to zero and put it into the handwheel after setting the variators to minimum speed. The gravitational indicator doesn't work with vertical handwheel axis.

Feet kit

CHV	02	05	10
A	110	120	160
B	105	104	125
C	145	149	190
D	120	125	150
E	15.5	20.5	26.5
F	9	9	11
G	10	12	14
H	82	93	113

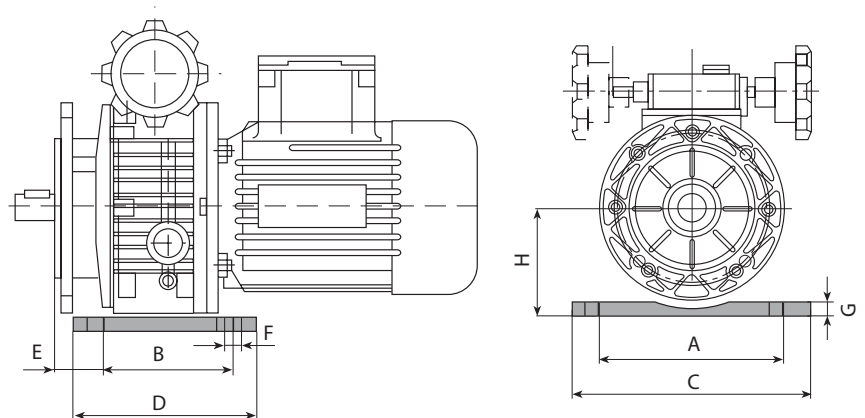



USE AND MAINTENANCE

- The screws under the handwheel are well adjusted, don't touch them.
- Don't adjust the handwheel when the motor is off, this can cause internal breaking.
- Speed variators are filled with oil, check the level before running.
- After the running-in the oil must be changed, check the level periodically.
- The temperature after the running-in can reach 50/55°C over room temperature.
- When the variator is supplied without motor make sure that the assembled one is at least "normal" class quality and the connection is not forced.
- Speed variators are supplied with closed oil plugs. When the variator is used for continuous work replace the closed plug with the supplied breather plug.



SPARE PART LIST

- | | |
|----|---------------------------------|
| 1 | OUTPUT SHAFT |
| 2 | PLANET SUPPORT |
| 3 | SLIDE BLOCK |
| 4 | REGULATING ORBIT |
| 5 | BALL RING |
| 6 | MOVING OUTER PLANETARY ORBIT |
| 7 | PLANET WHEEL |
| 8 | OPERATING BOX |
| 9 | FIXED OUTER PLANETARY ORBIT |
| 10 | FIXED INFERIOR PLANETARY ORBIT |
| 11 | MOVING INFERIOR PLANETARY ORBIT |
| 12 | BUTTERFLY SPRING |
| 13 | MOTOR SHAFT |

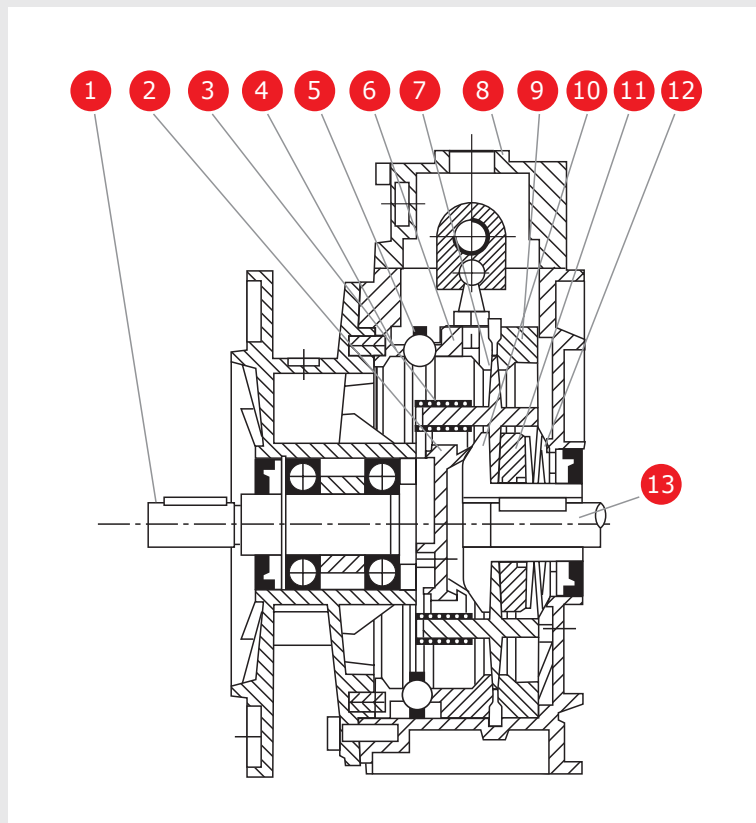



SYMBOLS

P = Power (Kw)
i = Ratio
T = Torque (Nm)
n = Speed (RPM)
Fr = Radial Load (N)
Fa = Axial Load (N)
f.s. = Service Factor
D = Diameter (mm)

1 Kw = 1,36 HP

9,81 N = 1 Kp

1 Input
 2 Output



GENERAL INFORMATION

POWER P

$P_1 \cdot \eta = P_2$
 P_1 = Input power
 P_2 = Output power
 η = Transmission efficiency

2

VELOCITA' DI ROTAZIONE n

n_1 = Input speed
 n_2 = Output speed

An output speed ≤ 1400 rpm is suggested so as to optimize the working condition and extend the service life.

TRANSMISSION RATIO i

$$i = \frac{n_1}{n_2}$$

TORQUE T

$$T_2 = \frac{9550 \cdot P_1 \cdot \eta}{n_2} \quad [\text{Nm}]$$

$$T_{2n} \geq T_2 \cdot f_s \quad [\text{Nm}]$$

T_2 = Output torque
 T_{2n} = Rated output torque
 P_1 = Input power
 η = Transmission efficiency
 f_s = Service factor

2D and 3D drawings available on the web site www.chiaravalli.com
 Quantity, availability and prices with Chiaravalli B2B



RADIAL LOADS F_R

The radial loads is proportional to the requested torque and inversely proportional to the transmission member diameter following this formula.

$$F_R = \frac{2000 \cdot T \cdot T.e.f.}{D} \left[N \right]$$

F_R = Radial load
 T = Nm (Torque)
T.e.f. = Transmission element factor
T.e.f. = 1,15 gear
= 1,4 chain spocket
= 1,75 v-pulley
= 2,5 flat-pulley
 D = Transmission element diameter

When the radial loads is not applied on the centre line of the shaft it is necessary to use the following formula.

$$F_{R_x} \leq \frac{F_R \cdot a}{(b+x)} \left[N \right]$$

F_R = Radial load on the centre line
 a, b, x = see tables page 9-46-47-77-78



LUBRICATION

All, gearboxes and variators are supplied, CHA type excluded, complete with lubricant. The gearboxes maintenance free are lubricated with synthetic oil the others with mineral oil. It is very important to verify the mounting position because sometimes adding some oil is enough, in other case to lubricate bearings with special grease would be necessary. Use only recommended oils.

Warning in case of heavy work it is better to install, where possible, breather plug.



PAINTING

All the gearboxes and electrical motors are painted Grey RAL 9022 with epoxy resins powder. Big gearboxes and motors are cast iron made, aluminium all the others.



SERVICE FACTOR F_s

The service factor mainly depends on three parameters:

- type to load: U - M - H
- run time: h/day
- start-up frequency: na/h

U = uniform
M = moderate
H = heavy
na/h = starts/hour

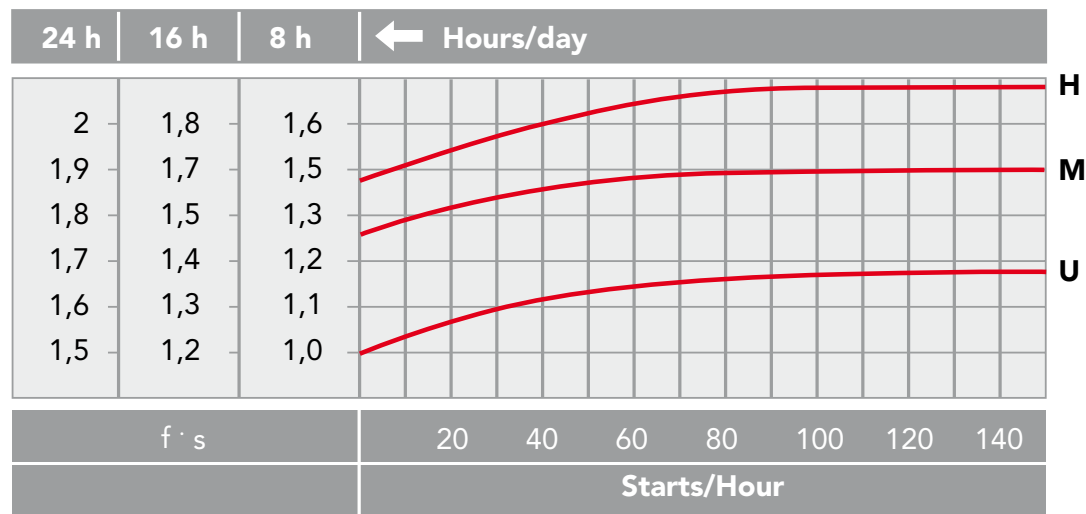

4

LOAD TYPE - APPLICATION

- U** Conveyor belts for light weights - centrifugal pumps - lifts - bottling machines
- M** Conveyor belts for heavy weights - packing machines - wood working machines - gear pumps
- H** Mixers - bucket elevators - tooling machines - machinery for bricks - vibrators



V6/B8 MOUNTING POSITION

When the worm gearboxes mounting position is V6 or B8, with continuous work or input speed >1400 p.p.m, it is necessary to call our technical service.

2D and 3D drawings available on the web site www.chiaravalli.com
 Quantity, availability and prices with Chiaravalli B2B