



Thomas AMR/CMR

Precision. Power. Performance.

You want a trusted name when it comes to providing engineered power transmission products that improve productivity and efficiency. Rexnord provides superior products for your industrial applications world wide. We work closely with you to reduce maintenance costs, eliminate redundant inventories and prevent equipment downtime.

Applications include:

- ▶ compressors
- ▶ mill drives
- ▶ conveyors
- ▶ crushers

Thomas AMR/CMR

The Thomas AMR/CMR couplings are used in heavy duty slow to medium speed applications where shock loads, torque reversals or continuous alternating torque is present. CMR design uses a flywheel adapter plate to bolt directly to the flywheel of an engine or compressor.



Ex II 2G T5

Thomas AMR/CMR

Features

- ▶ Unitized disc pack (Tpack)
- ▶ Cast hubs and cmbr
- ▶ High overload capacity
- ▶ Flywheel adapter

Benefits

- ▶ Ease of installation
- ▶ Damping capacity
- ▶ Reciprocating applications
- ▶ Reciprocating compressor mount

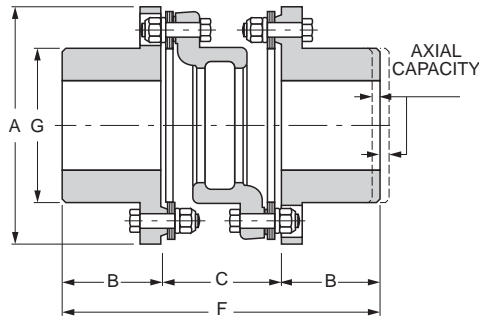

Torque Demands Driven Machine	Typical Application for Electric Motor or Turbine Driven Equipment	Typical Service Factor
	Constant torque such as centrifugal pumps blowers and compressors	1.0
	Continuous duty with some torque variations including plastic extruders and forced draft fans	1.5
	Light shock loads from metal extruders, cooling towers and log haulers	2.0
	Moderate shock loading as expected from a car dumper, stone crusher, vibrating screen	2.5
	Heavy shock load with some negative torques from reciprocating pumps, compressors, reversing turnout tables	3.0
	Frequent torque reversals such as reciprocating compressors with frequent torque reversals which do not necessarily include reverse rotations	Consult Rexnord Engineering

General dimensions AMR

Coupling Size	Rough Bore (mm)	Max. Bore (mm)	A (mm)	B (mm)	C (mm)	F (mm)	G (mm)
162	-	42	116	44.5	66.5	155	70
200	-	52	146	53.8	76.2	184	92
225	-	58	152	63.5	76.2	203	99
262	-	70	175	73.2	88.9	235	114
312	-	84	206	85.9	104.6	276	138
350	-	95	232	95.3	115.8	306	152
375	-	100	256	101.6	130.0	333	165
425	-	114	279	108.0	141.2	357	178
450	-	120	302	114.3	150.9	379	189
500	68	137	341	127.0	173.0	427	213
550	68	150	381	139.7	195.3	475	240
600	94	166	425	152.4	214.4	519	262
700	108	195	481	177.8	244.3	600	298
750	125	205	524	184.2	266.7	635	321
800	132	225	568	196.9	289.1	683	349
850	138	234	603	209.6	307.8	727	368
925	151	240	654	228.6	336.6	794	403

Engineering data AMR

Coupling Size	Max. RPM	Max. Continuous Torque (Nm)	Peak Overload Torque (Nm)	Weight (Kg)	WR ² (Kgm ²)	Axial Capacity (mm)
162	2 500	648	778	3.6	0.005	±0.91
200	2 500	1 245	1 494	7.3	0.017	±0.91
225	2 500	1 758	2 110	9.1	0.022	±0.91
262	2 500	2 375	2 850	14.5	0.047	±1.09
312	2 500	2 670	3 204	21.3	0.107	±1.29
350	2 300	5 961	7 153	32.2	0.193	±1.42
375	2 200	8 968	10 762	41.8	0.300	±1.57
425	2 000	9 935	11 921	53.1	0.465	±1.70
450	1 900	15 367	18 441	65.4	0.658	±1.82
500	1 800	22 663	27 196	96.2	1.241	±2.02
550	1 800	31 052	37 262	131.7	2.113	±2.33
600	1 800	40 514	48 617	176.6	3.511	±2.59
700	1 500	51 535	61 842	266.5	6.671	±2.92
750	1 500	72 808	87 369	327.8	9.919	±3.17
800	1 200	91 869	110 243	425.9	16.269	±3.45
850	1 100	101 456	121 748	522.1	22.121	±3.65
925	1 000	144 647	173 576	635.6	29.845	±3.96

Coupling Size

Flywheel Adapter CMR - Adapters Available in Shaded Sizes (Sizes 925 to 1505 - Adapting dimensions on request)

Adapter Tolerance	8 500	9 500	10 375	12 375	13 875	16 000	18 375	20 375	22 500	26 500	28 875
162	8 498	9 498	10 373	12 373	13 873	15 998	18 373	20 372	22 497	26 497	28 872
200											
225											
262											
312											
350											
375											
425											
450											
500											
550											
600											
700											
750											
800											
850											



REXNORD NV, Belgium

Dellingstraat 55

2800 Mechelen

Phone: +32 / 70 22 33 66

Fax: +32 / 70 22 33 67

E-mail: Customerservice.Belgium@rexnord.com

www.rexnord.eu

Contact